



AD-120i Parts Manual

Whirlpool Corporation

88 Currant Road, Fall River MA 02720-4781 USA

Telephone: +1 (269) 759-6044

e-mail: mdl-parts@whirlpool.com

www.adclaundry.com

Retain This Manual In A Safe Place For Future Reference

ADC products embody advanced concepts in engineering, design, and safety. If this product is properly maintained, it will provide many years of safe, efficient, and trouble free operation.

ONLY qualified technicians should service this equipment.

OBSERVE ALL SAFETY PRECAUTIONS displayed on the equipment or specified in the installation manual included with the dryer.

The following “**FOR YOUR SAFETY CAUTION**” must be posted near the dryer in a prominent location.

FOR YOUR SAFETY

Do not store or use gasoline or other flammable vapors and liquids in the vicinity of this or any other appliance.

POUR VOTRE SÉCURITÉ

Ne pas entreposer ni utiliser d'essence ni d'autres vapeurs ou liquides inflammables à proximité de cet appareil ou de tout autre appareil.

We have tried to make this manual as complete as possible and hope you will find it useful. ADC reserves the right to make changes from time to time, without notice or obligation, in prices, specifications, colors, and material, and to change or discontinue models.

Important

For your convenience, log the following information:

DATE OF PURCHASE _____ MODEL NO. **AD-120i**

RESELLER'S NAME _____

Serial Number(s) _____

The illustrations on the following pages may not depict your particular dryer exactly. The illustrations are a composite of the various dryer models. Be sure to check the descriptions of the parts thoroughly before ordering.

“IMPORTANT NOTE TO PURCHASER”

Information must be obtained from your local gas supplier on the instructions to be followed if the user smells gas. These instructions must be posted in a prominent location near the dryer.

Table of Contents

Non-Coin Control Door Assembly	4
Phase 7 Non-Coin Microprocessor Control Box Assembly	5
Front Panel Assembly	6
Main Door Assembly	7
Main Door Switch Assembly	8
Tumbler / Support Assemblies	9
Front Support Wheels	10
Lint Coop Sensor Assemblies	11
Lint Door Assembly	12
Lint Trap Assembly	13
Lint Door Support Assembly	14
Tumbler Bearing Assembly	15
Blower Motor Mount Assembly	16
Drive Motor Mount Assembly	17
Gas Burner Assembly	18
Direct Spark Ignition Module Assembly	19
Electric Oven Assemblies	20
Electric Oven Transition Plenum	21
Electric Heat Contactor Box	22
Rear Heat Duct Assembly	23
Steam Coil Assembly	24
Rear Electrical Panel Assembly	25
Sail Switch Assembly	26
VFD Panel	27
Outer Top / Back Guard Assemblies	28
Fire Suppression Assembly	29
Additional Parts Available	30

Non-Coin Control Door Assembly

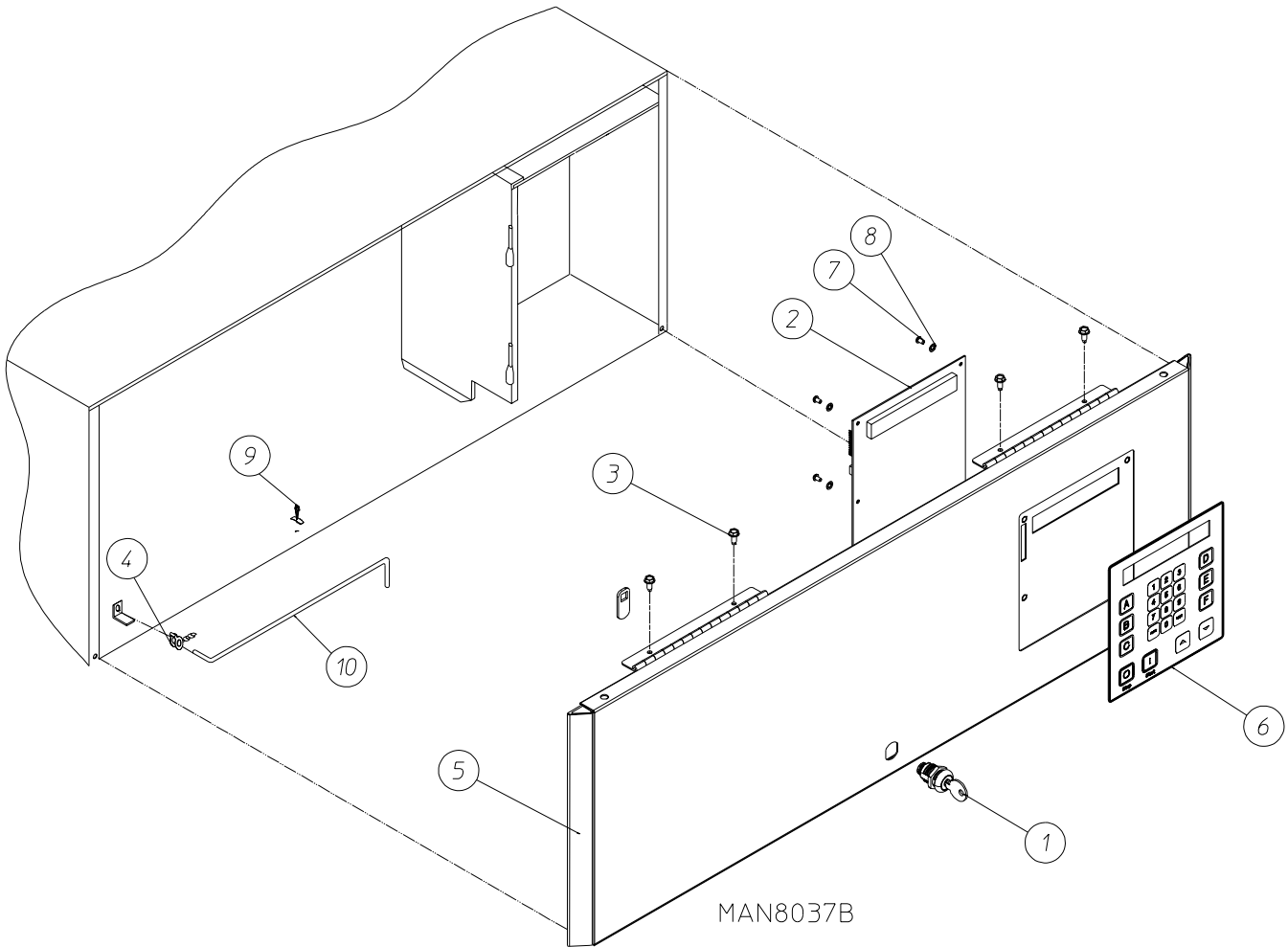

Illus. No.	Part No.	Qty.	Description
1	160015	1	Lock and Key
	160032	1	1" Straight Cam
2*	884595	1	Phase 7.2 Non-Coin Computer with S.A.F.E. System Option (Language English, Spanish, French, and German)
	884599	1	Phase 7.2 Non-Coin Computer without S.A.F.E. System Option (Language English, Spanish, French, and German)
3	150300	6	#10-16 x 3/4" TORX PLUS® BTN Type 1
4	102601	1	Control Door Retainer Clip
5	812095	1	Non-Coin Control Door (for models mfd. as of June 12, 2015)
	812048	1	Non-Coin Control Door with Graphics (for models mfd. prior to June 12, 2015)
6	112610	1	Phase 7.2 Non-Coin Keypad (blue)
7	150005	5	#6-32 x 1/4" Phillips Screw
8	153010	4	#6 Star Washer
9	102603	1	Control Door Rod Support Catch
10	312097	1	Control Door Support Rod

* For additional language options contact factory.

Phase 7 Non-Coin Microprocessor Control Box Assembly

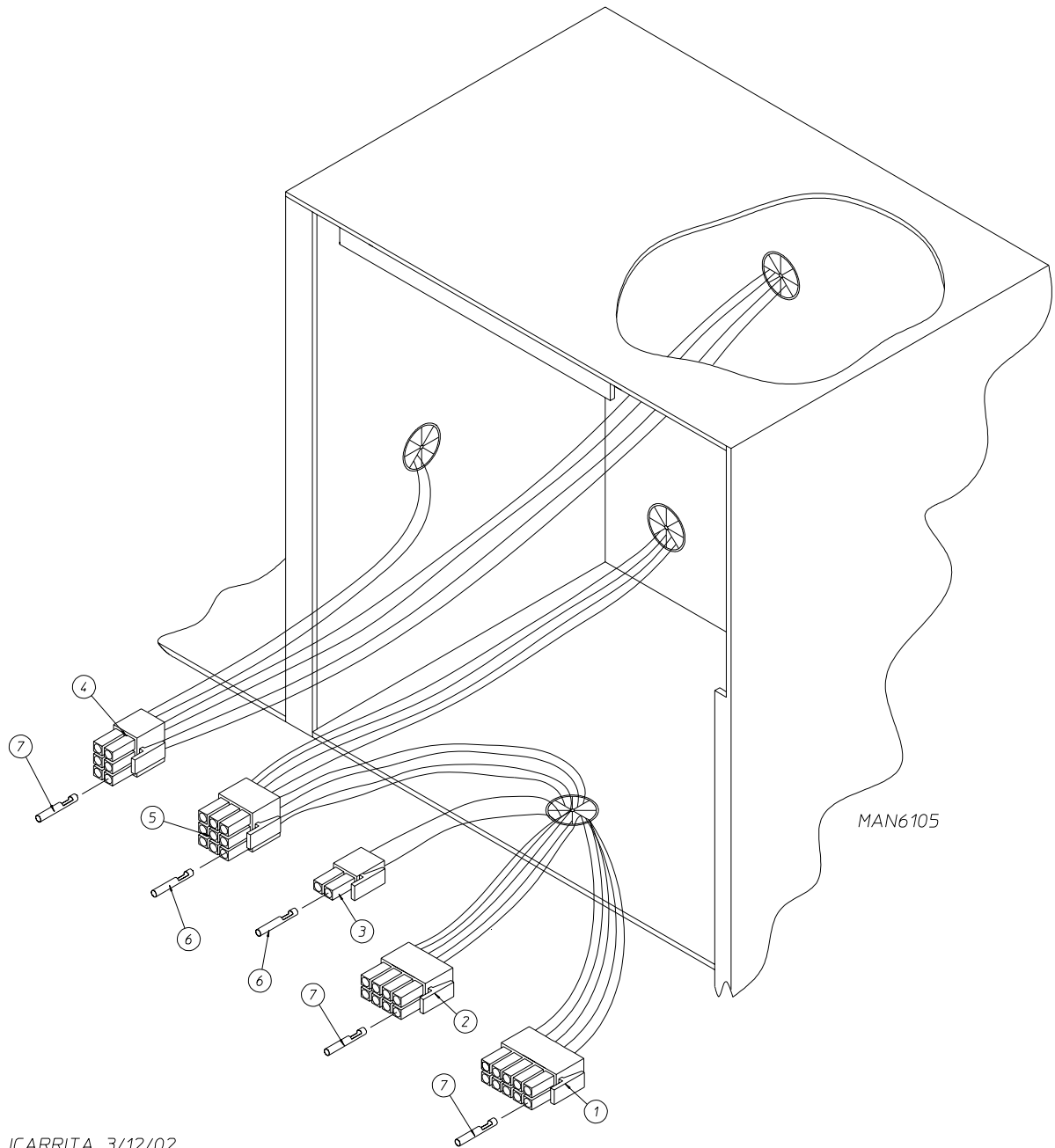

Illus. No.	Part No.	Qty.	Description
1	122681	1	10-Pin Connector
2	122676	1	8-Pin Connector
3	122646	1	2-Pin Connector
4	122683	1	6-Pin Terminal
5	122640	1	9-Pin Terminal
6	122706	*	#20-16 U.M.N.L. Socket
7	122669	*	Female Crimp Terminal

* As needed.

Front Panel Assembly

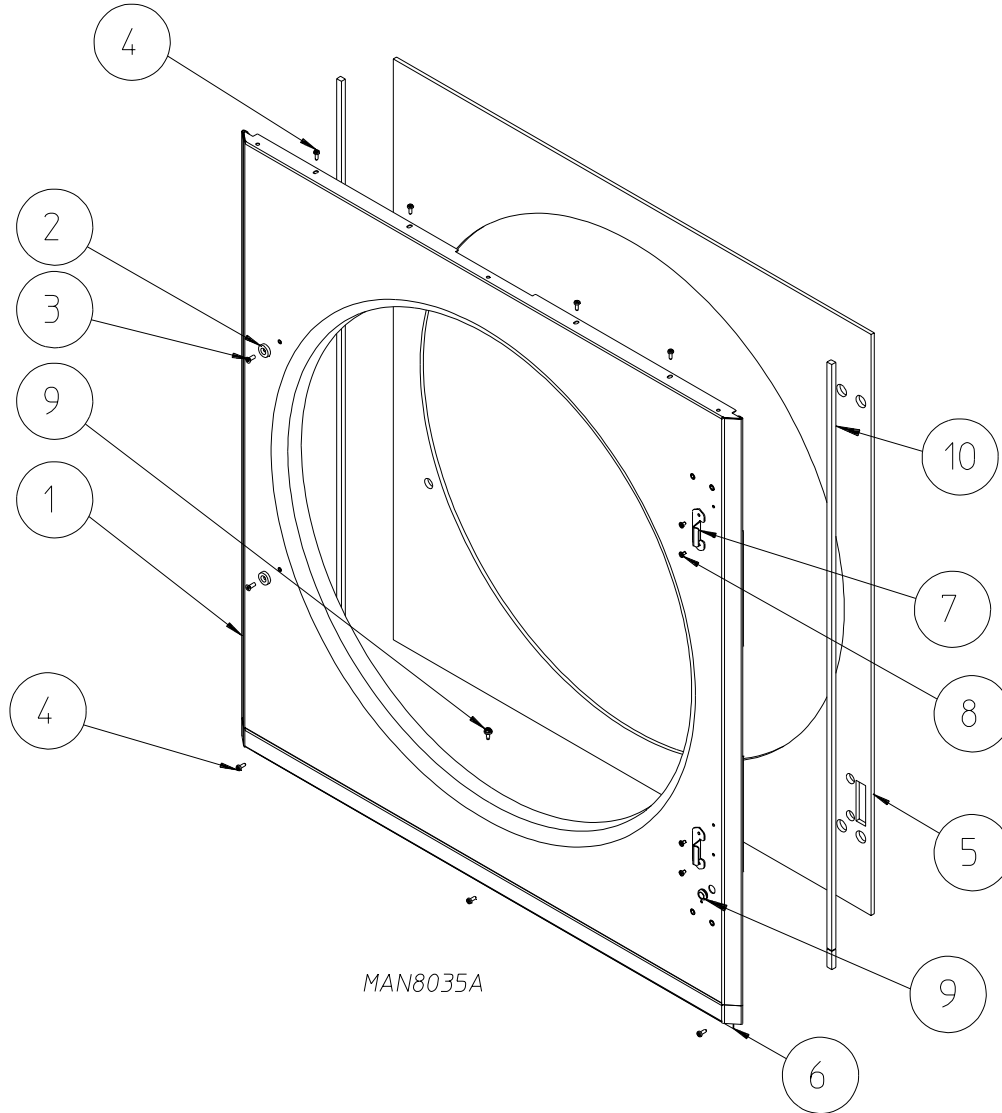

<u>Illus. No.</u>	<u>Part No.</u>	<u>Qty.</u>	<u>Description</u>
1	812100	1	Front Panel Assembly (includes illus. nos. 1 through 10) (for models mfd. as of June 12, 2015)
	812092	1	Front Panel Assembly (includes illus. nos. 1 through 10) (for models mfd. prior to June 12, 2015)
2	102004	2	Compact Door Magnet
3	152223	2	#10-32 x 1/2" Machine Screw
4	150313	10	#10-16 x 1/2" Pan Head TORX® Screw
5	116362	2	Front Panel Insulation
6	312409	1	Front Panel Trim
7	335508	2	Door Stop
8	154205	4	5/32" x 1/4" Stainless Steel Rivet
9	121401	1	Rubber Grommet
10	117617	8	Foam Gasket (sold by the foot)
—	116028	1	Front Panel Felt Gasket ... Not Illustrated
	401010	1	Adhesive for Felt Collar

Main Door Assembly

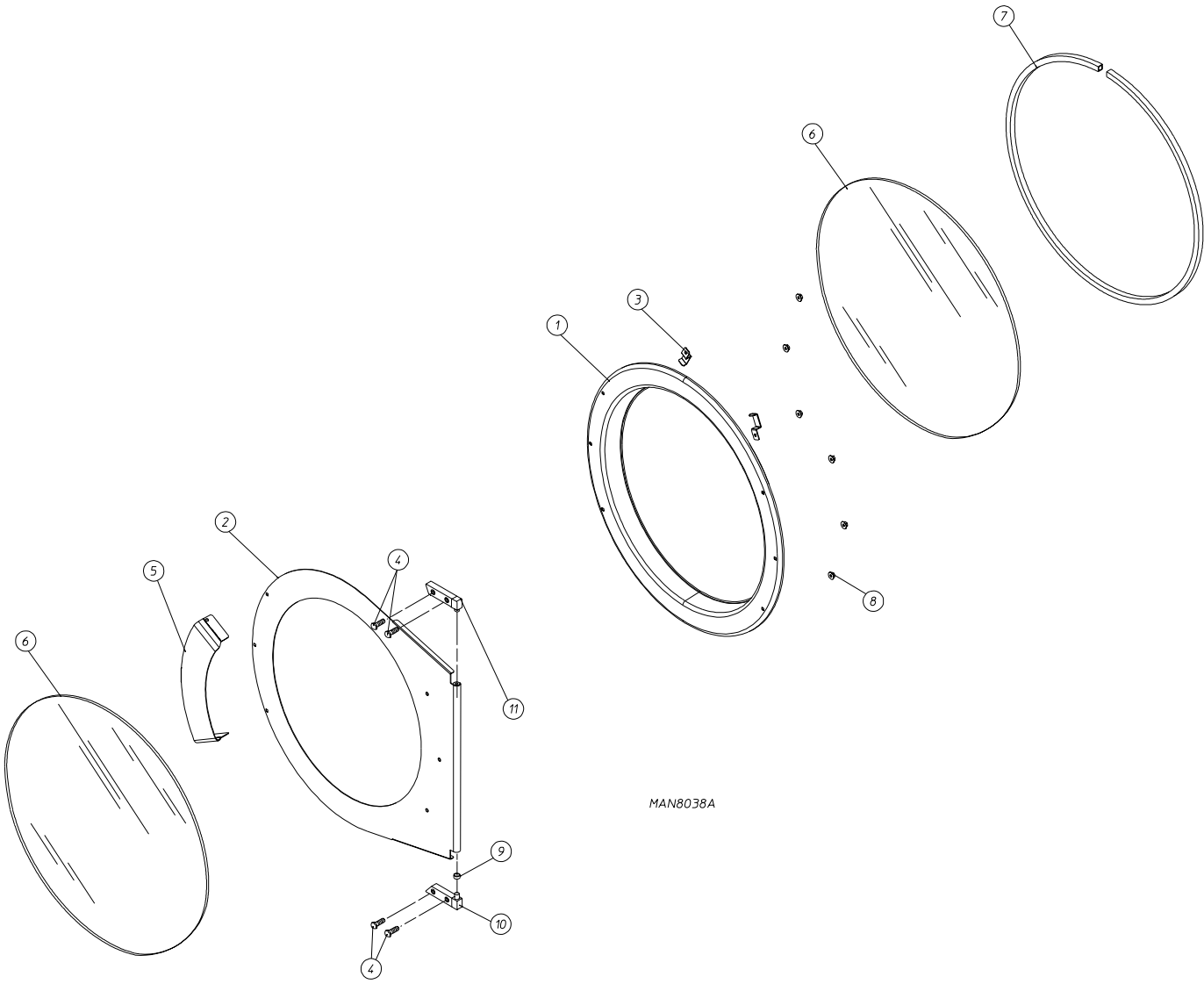

MAN8038A

<u>Illus. No.</u>	<u>Part No.</u>	<u>Qty.</u>	<u>Description</u>
1	817750	1	Main Door Assembly Complete (includes illus. nos. 1 through 8)
	835617	1	Main Door Ring Assembly (includes illus. nos. 1, 6, and 7)
2	817749	1	Door Outer Skin Assembly (includes illus. nos. 2 and 6)
3	319298	2	Magnet Bracket
4	150445	4	1/4-20 x 3/4" Black Cap Head Setscrew
5	817751	1	Door Handle Assembly
6	102227	2	Main Door Glass
	401038	1	Black Glass Adhesive (10.3 oz. cartridge)
7	882411	1	Door Gasket
	401038	1	Black Gasket Adhesive (10.3 oz. cartridge)
8	152014	6	1/4-20 Free Spin Wash Nut
9	153031	1	1/4" Nylon Washer
10	881151	1	Black Bottom Hinge Block Assembly (includes illus. nos. 4, 9, and 10)
11	881152	1	Black Top Hinge Block Assembly (includes illus. nos. 4 and 11)

Main Door Switch Assembly

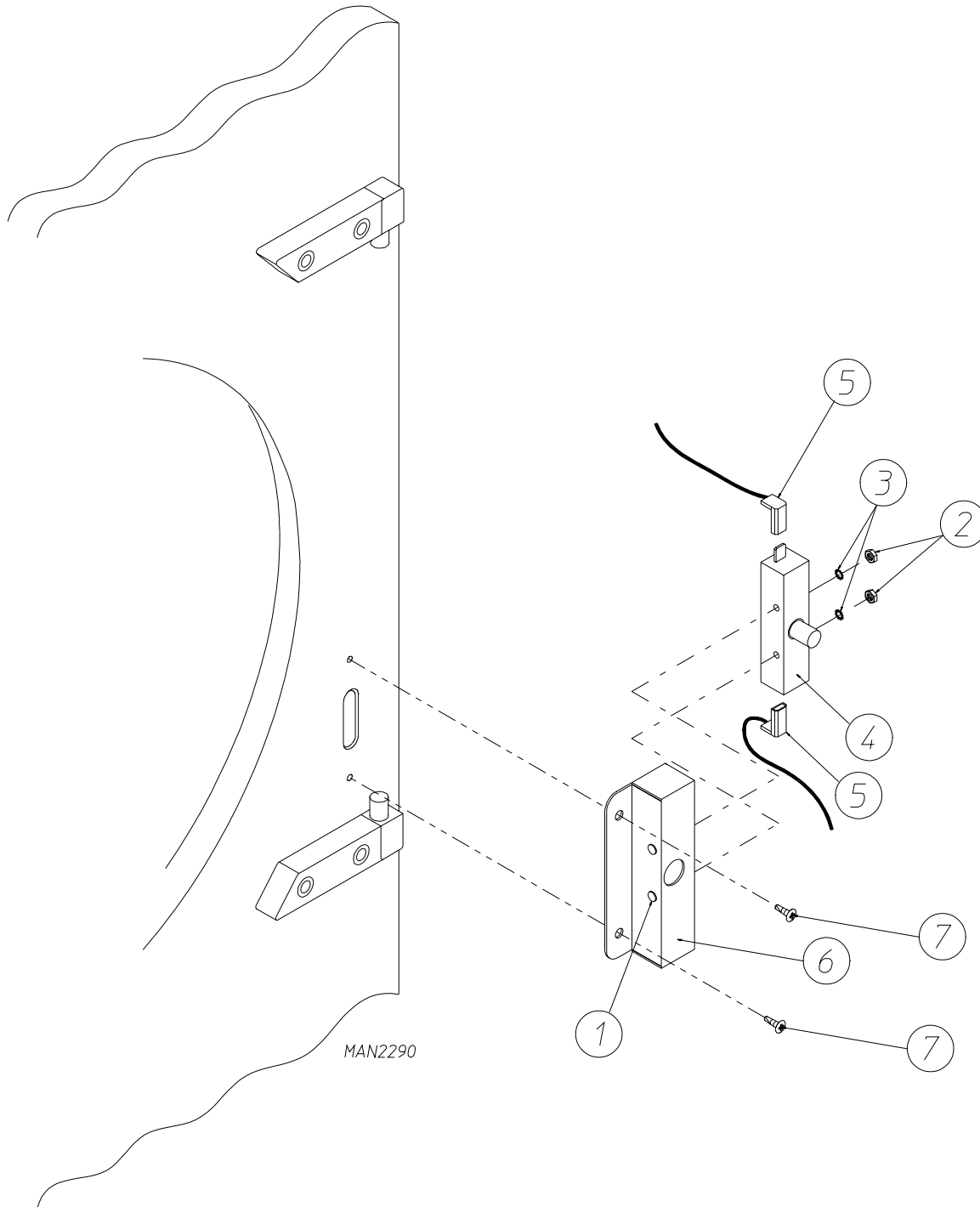

Illus. No.	Part No.	Qty.	Description
1	150006	2	#6-32 x 7/8" Phillips Pan Head Machine Screw
2	152013	2	#6-32 Hex Nut
3	153010	2	#6 Star Washer
4	137005	1	Door Switch
5	122636	2	Flag Terminal
6	881211	1	Black Main Door Switch Housing ONLY
	881153	1	Black Main Door Switch Housing Complete (includes illus. nos. 1 through 4 and 6)
7	150301	2	#8-18 x 7/16" Phillips Pan Head TEK Screw

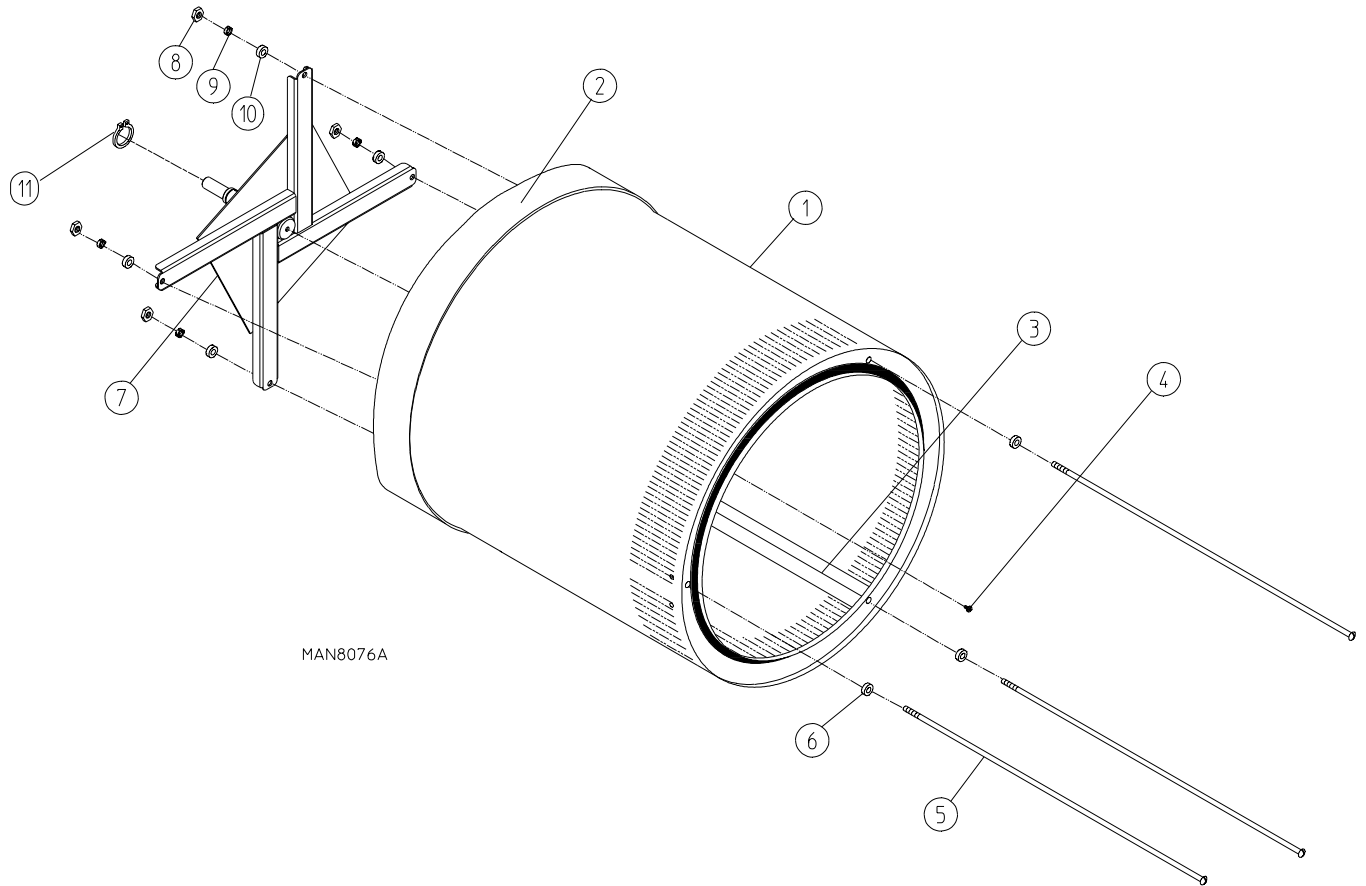

MAN8076A

Illus. No.	Part No.	Qty.	Description
1	812001	1	Stainless Steel Tumbler / Support Assembly (includes illus. nos. 1 through 11)
2	115933	1	Rear Felt Collar
3	312003	4	Stainless Steel Tumbler Rib
4	150407	1	5/16-18 x 3/4" Socket Button Head Screw
5	100922	4	1/2-13 x 45-3/8" Hex Head Tie Rod
6	153004	4	3/8" Flat Washer
7	812000	1	Tumbler Support
8	152028	4	1/2-13 Hex Nylon Insert Lock Nut
9	153026	4	1/2" Lock Washer
10	153011	4	9/16" Flat Washer
11	100812	1	1-3/8" Retaining Clip
—	401010	1	#847 Adhesive for Felt Collar (5.0 oz. tube)

Front Support Wheels

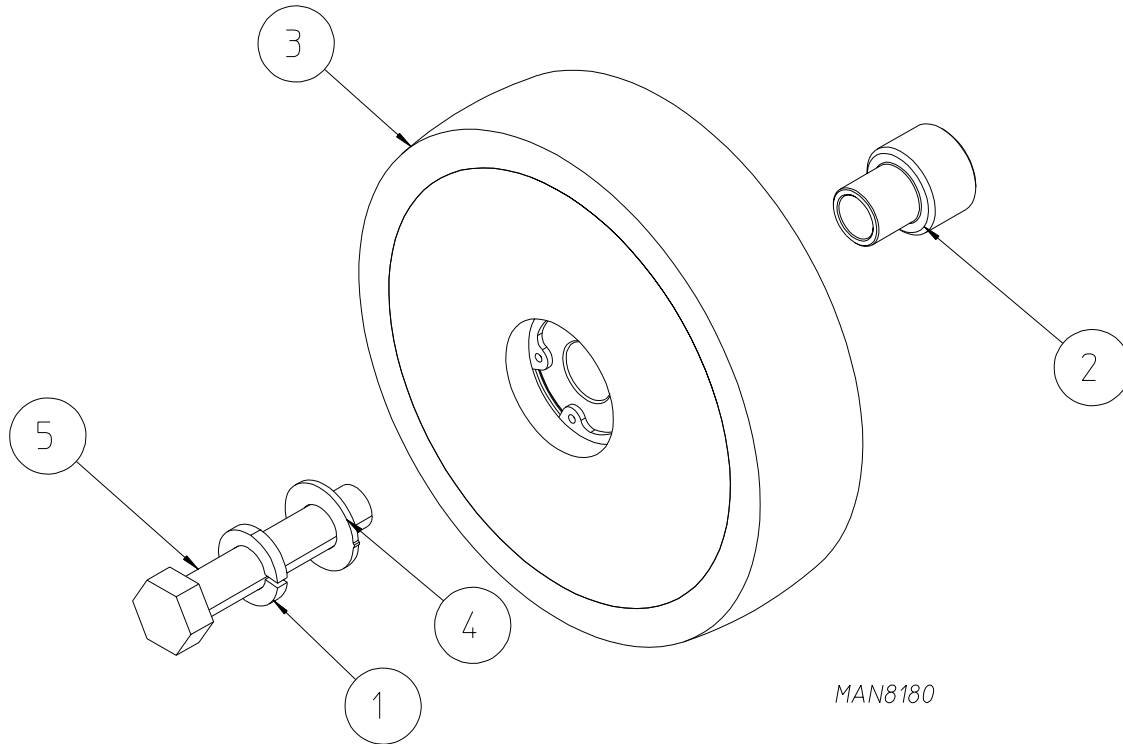

<u>Illus. No.</u>	<u>Part No.</u>	<u>Qty.</u>	<u>Description</u>
1	153026	1	1/2" Lock Washer
2	312209	1	Tumbler Wheel Spacer
3	180023	1	Tumbler Wheel
4	312212	-	Flat Washer
5	150620	1	1/2-13 x 2-1/2" Bolt

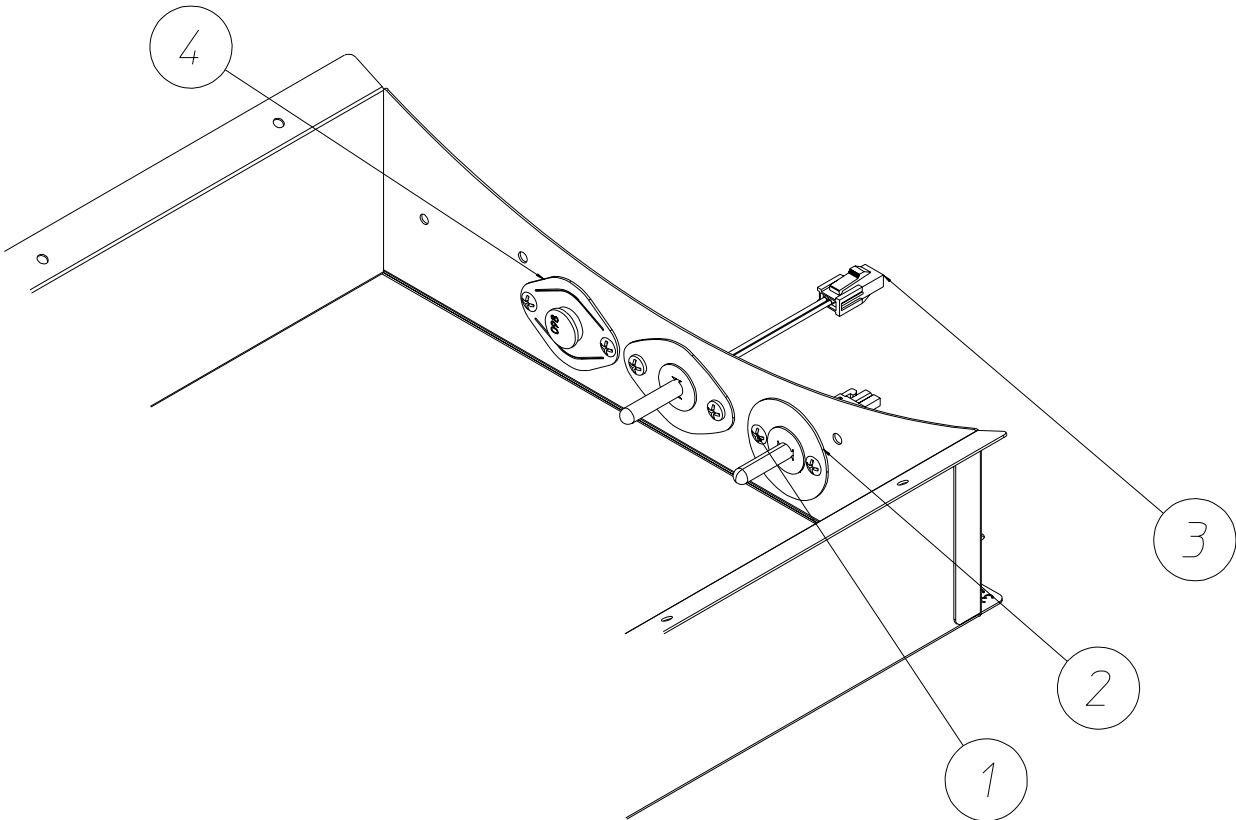

MAN8040

Illus. No.	Part No.	Qty.	Description
1	150301	6	#8-18 x 7/16" Phillips Pan Head TEK Screw
2	819188	1	Variable Speed Temperature Sensor Assembly
3	833522	1	1/4" Exhaust Temperature Sensor Probe Assembly
4	130301	1	225° Hi-Limit Thermostat

Lint Door Assembly

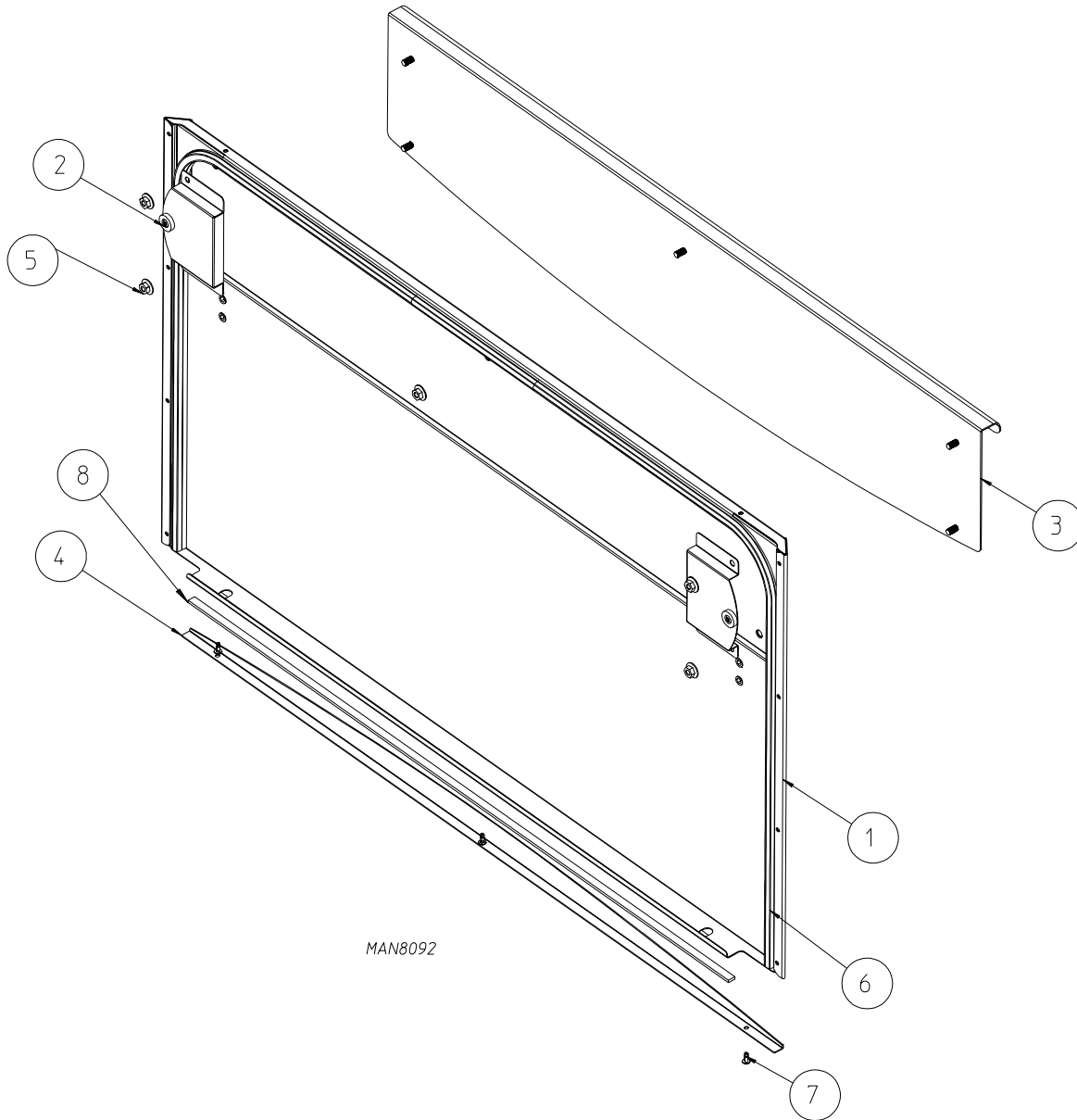

Illus. No.	Part No.	Qty.	Description
1	812152	1	Stainless Steel Drop Lint Door Assembly (includes illus. nos. 1 through 8) (for models mfd. as of June 12, 2015)
	812090	1	Stainless Steel Drop Lint Door Assembly (includes illus. nos. 1 through 8) (for models mfd. prior to June 12, 2015)
2	835650	2	Lint Door Magnet Catch and Lint Switch Actuator
3	817759	1	Drop Lint Door Handle Stud Assembly (for models mfd. as of June 12, 2015)
	812089	1	Drop Lint Door Handle Stud Assembly (for models mfd. prior to June 12, 2015)
4	312091	1	Drop Lint Door Bottom Trim
5	152014	9	1/4-20 Serrated Hex Flange Nut
6	102420	84	.375 Rubber Gasket (sold by the inch)
7	154205	3	5/32" x 1/4" Stainless Steel Rivet
8	117604	4	.375 x .125 Neo Sponge Tape

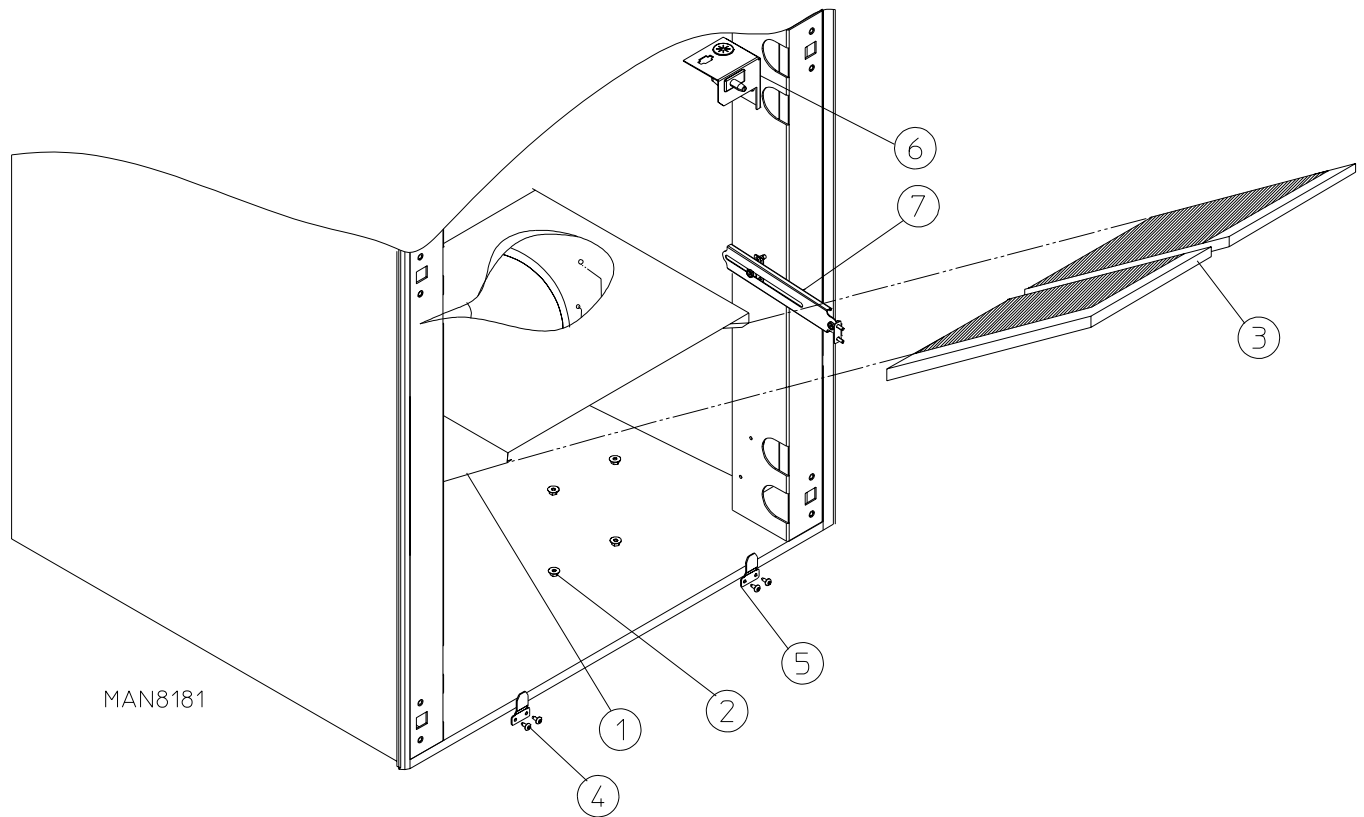

<u>Illus. No.</u>	<u>Part No.</u>	<u>Qty.</u>	<u>Description</u>
1	812024	1	Lint Trap Assembly Complete (includes illus. nos. 1 and 3 through 5)
	812023	1	Lint Trap ONLY
2	152014	8	1/4-20 Flange Nut
3	108206	2	Lint Screen
	312054	1	Lint Screen Holder ONLY
4	150313	4	#10-16 x 1/2" TORX® Screw
5	335560	2	Lint Door Hold Down Bracket
6	835571	1	Lint Switch Bracket Assembly
	122116	1	Lint Switch ONLY
7	_____	1	Lint Door Support Assembly (Parts Breakdown on page 14)

Lint Door Support Assembly

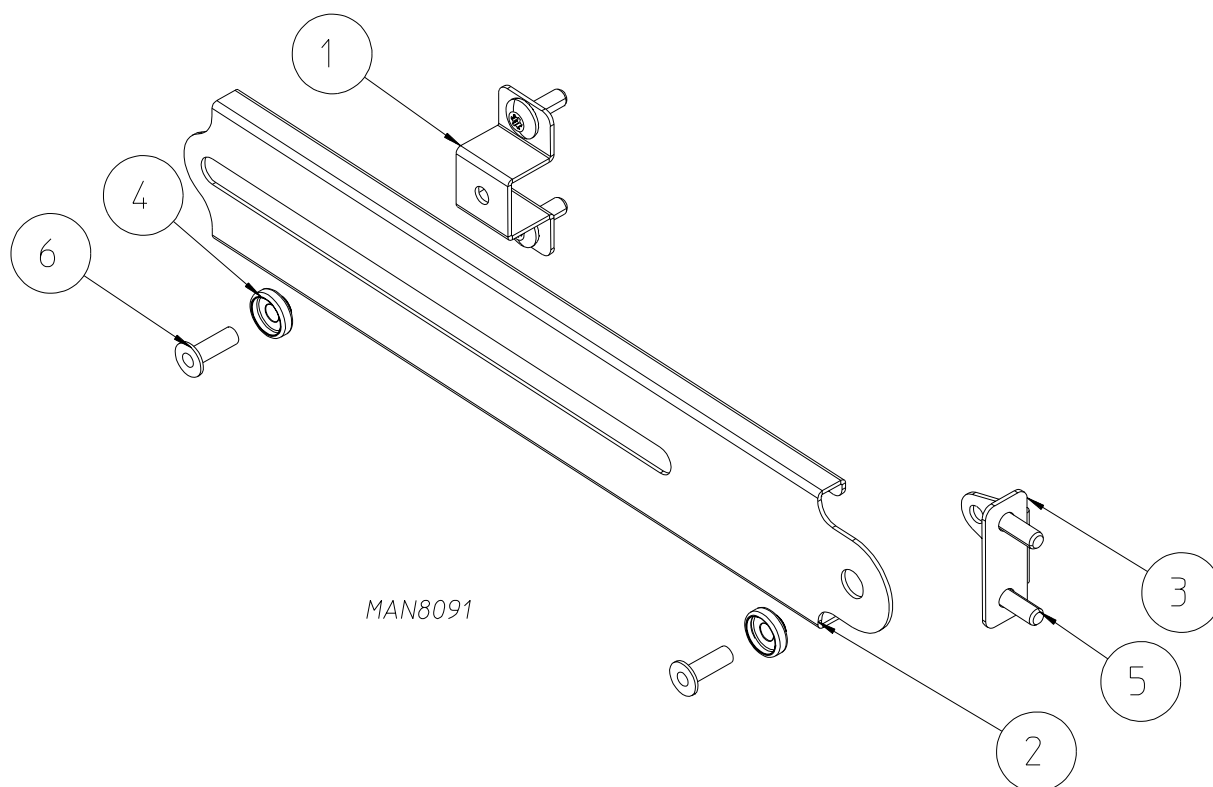

<u>Illus. No.</u>	<u>Part No.</u>	<u>Qty.</u>	<u>Description</u>
1	335551	1	Drop Lint Door Support Mount
2	335549	1	Drop Lint Door Support Slide Arm
3	335550	1	Drop Lint Door Support Bracket
4	183008	2	Keyhole Button
5	183129	4	#10-32 x 1/2" TORX® Truss Head Machine Screw
6	154220	2	3/16" Pop Rivet

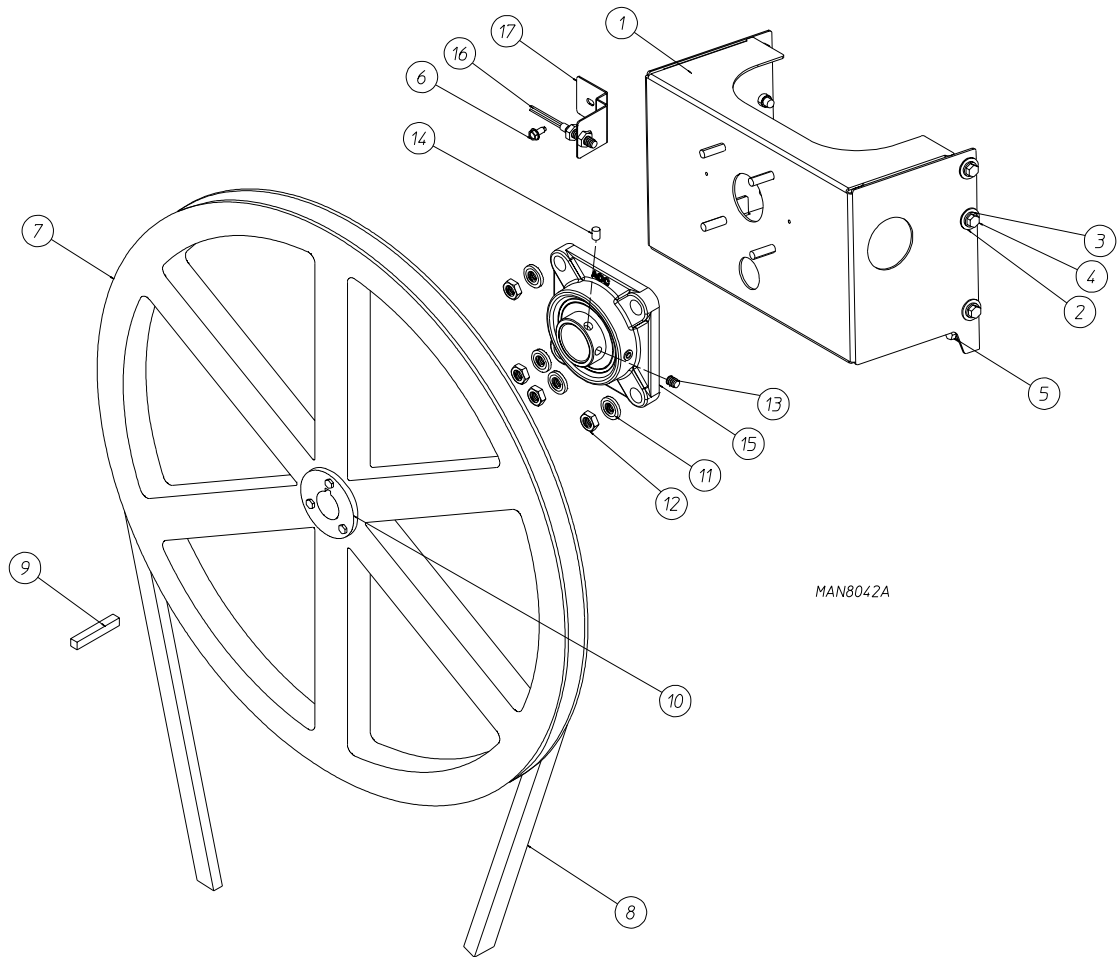

Illus. No.	Part No.	Qty.	Description
1	812012	1	1-3/8" Flange Bearing Mount (includes illus. nos. 1 and 3)
	812011	1	Bearing Mount ONLY
2	153004	6	Flat Washer
3	153005	6	Lock Washer
4	150617	8	Hex Head Machine Bolt
5	152005	2	Hex Nut
6	150300	1	#10-16 x 1/2" Hex Washer TEK
7	101257	1	24.75" 15 Groove Pulley
8	102429	1	15 Rib J-Belt
9	100717	1	5/16" x 2-3/4" Key
10	121410	1	1-3/8" Bushing
11	153005	4	3/8" Lock Washer
12	152005	4	3/8-16 Hex Nut
13	154321	2	Setscrew
14	170608	1	0.25 x 0.25 Magnet
15	884485	1	1-3/8" Flange Bearing Assembly (includes illus. nos. 2, 13, and 14)
16	822735	1	Rotation Sensor
17	835596	1	Rotation Sensor Assembly (includes illus. nos. 4 through 6)

Blower Motor Mount Assembly

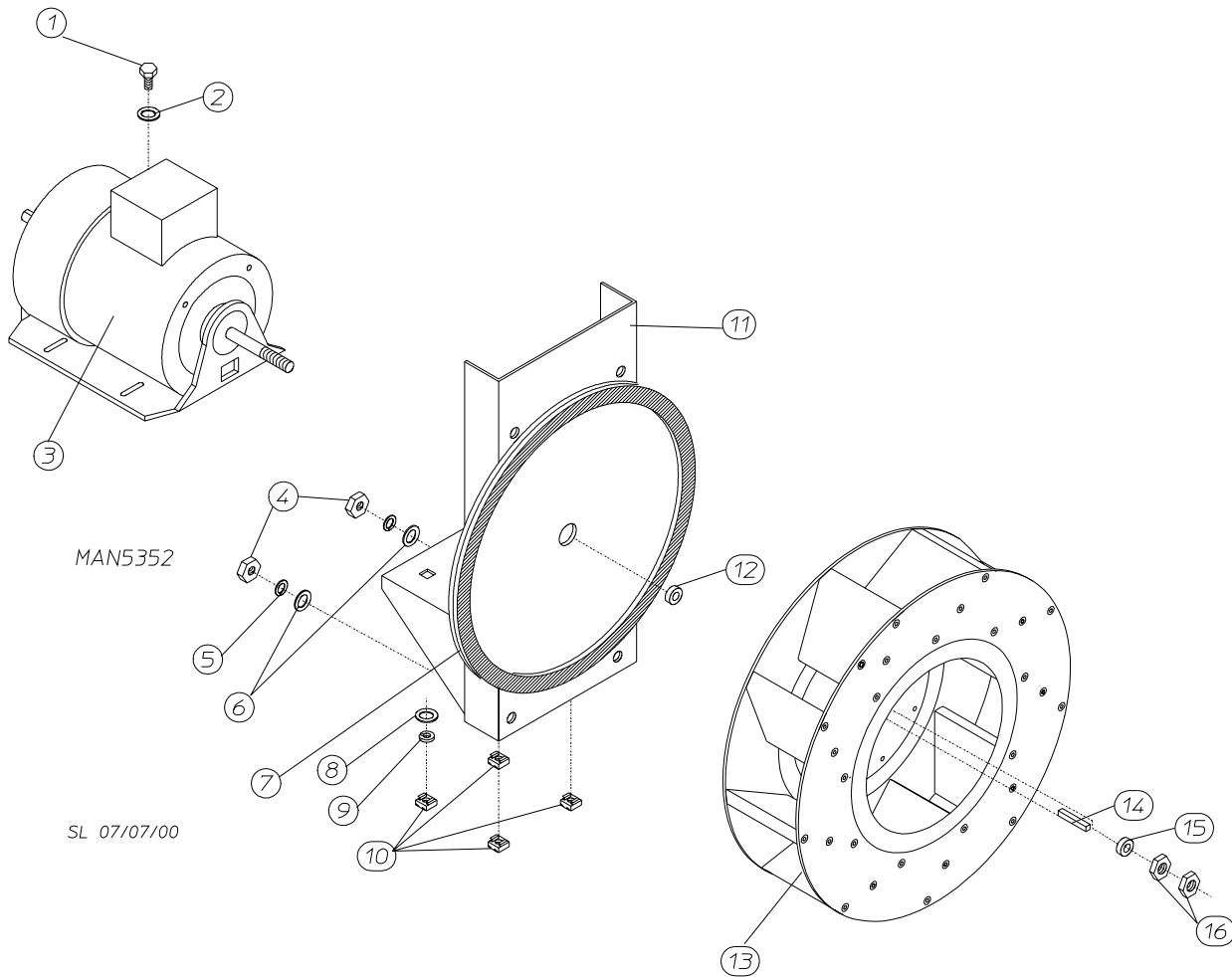

Illus. No.	Part No.	Qty.	Description
1	150501	4	5/16-18 x 3/4" Tap Bolt
2	153001	4	5/16" Flat Washer
3	100075	1	1 hp 208-480V 3ø Motor (for gas and electric models)
	100073	1	1 hp 120-240V 1ø 60 Hz Fan Motor with Plug (for gas and electric models)
	181043	1	3 hp 208-480V 3ø Motor (for steam models)
4	152004	4	5/16-18 Hex Nut
5	153002	4	5/16" Lock Washer
6	153001	4	5/16" Flat Washer
7	117604	5	Noise Suppressor Tape (sold by the foot)
8	153001	4	5/16" Flat Washer
9	153002	4	5/16" Lock Washer
10	154000	4	5/16-18 Tinnerman Nut
11	153002	4	5/16" Lock Washer
	812014	1	Motor Mount ONLY (56Z frame)
	812066	1	1 hp 208-480V 3ø Fan Motor Mount Assembly Complete (for gas and electric models)
	812013	1	1 hp 208-240V 1ø 60 Hz Fan Motor Mount Assembly Complete with Plug Motor (for gas and electric models)
	812110	1	3 hp 208-480V 3ø Fan Motor Assembly (for steam models)
12	153055	1	5/8" Flat Washer
13	802026	1	16" Impellor with 3/4" Bore (for gas and electric models)
	812109	1	16-1/16" Impellor with 7/8" Bore (for steam models)
14	100705	1	3/16" x 3/16" x 1-3/8" Key
15	153050	2	1/2" S.A.E. Flat Washer
16	152006	2	1/2-20 Left-Hand Jam Nut

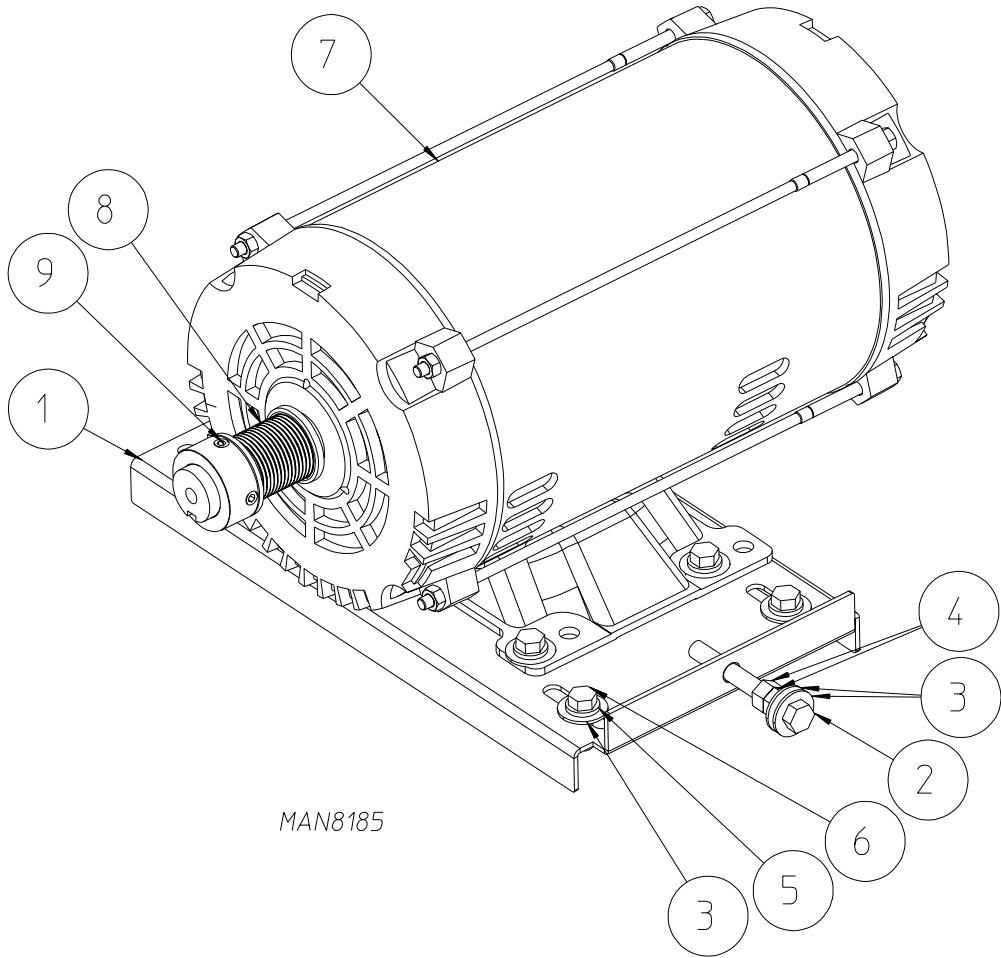

MAN8185

<u>Illus. No.</u>	<u>Part No.</u>	<u>Qty.</u>	<u>Description</u>
1	812061	1	Drive Motor Carriage
2	150619	1	3/8-16 x 3" Head Tap Bolt
3	153004	10	.375 Flat Washer
4	152005	2	3/8-16 Hex Nut
5	153005	8	3/8" Lock Washer
6	150617	8	3/8-16 x 1" Head Machine Bolt
7	181177	1	2 hp Motor 6-Pole 3ø Motor
8	312211	1	Sheave
9	154384	2	Setscrew

Gas Burner Assembly

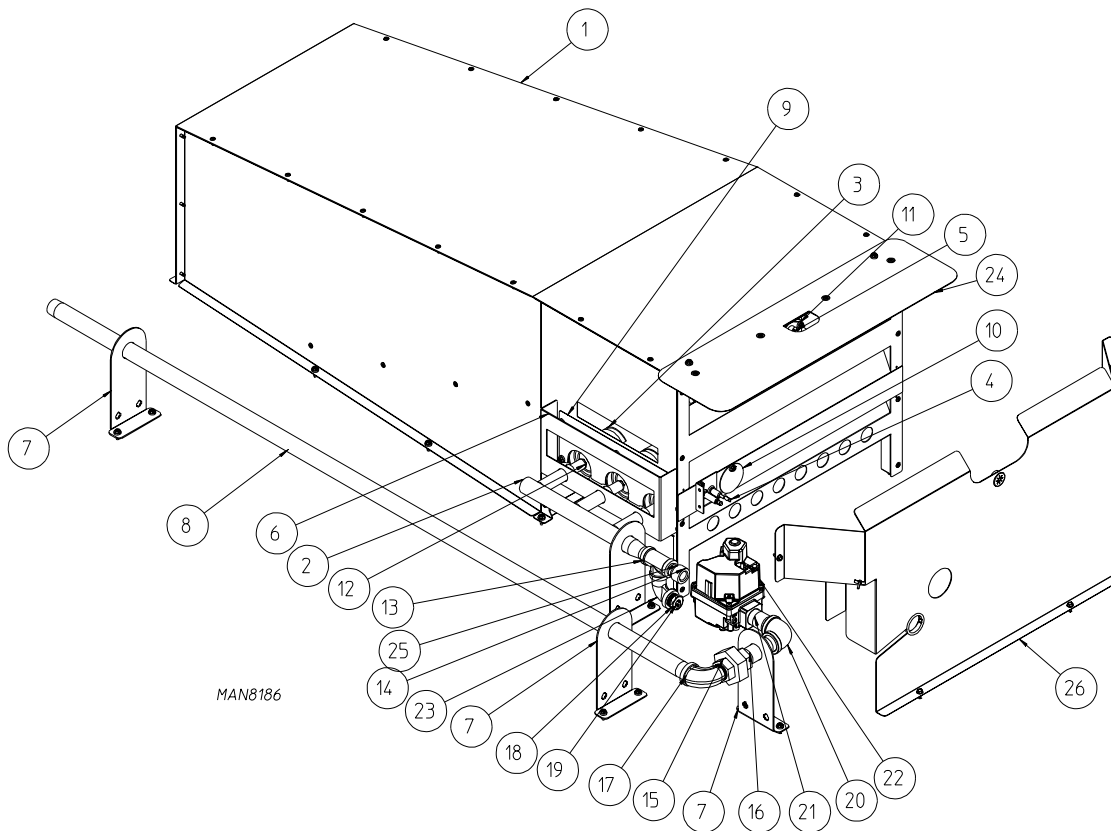

<u>Illus. No.</u>	<u>Part No.</u>	<u>Qty.</u>	<u>Description</u>
1	812009	1	Burner Box
2	141219	1	3-Port Manifold
3	141137	3	Burner Tube
4	128915	1	Ignitor with Flame Probe
5	130201	1	330° F Manual Reset Thermostat
6	312074	1	3 Tube Burner Manifold Rest
7	312073	4	Gas Pipe Bracket
8	142890	1	3/4" N.P.T. Black Iron Nipple 55" Long
9	312075	1	Burner Box Cover Plate
10	331290	1	Ignitor Sight Hole Disc
11	150309	32	#10-16 x 1/2" Hex Head Tek Crimptite Screw
12	140829	3	#18 Orifice for Natural Gas
	140815	3	#37 Orifice for Propane Gas
	884526	1	AD-120i Propane Conversion Kit (CSA approved dryers)
	884518	1	AD-120i Propane Conversion Kit (CE approved dryers)
13	142820	1	1/2" x 1/2" x 1/2" Tee
14	143167	1	3/4-1/2" Reducing Bushing
15	142601	1	3/4" Union
16	142708	1	3/4" N.P.T. by 3" Long Black Iron Nipple
17	142854	1	3/4" x 3/4" Street Elbow
18	143028	1	1/2" by 1/8" B.I. Hex Reducing Bushing
19	143029	1	0.125 N.P.T. Hex Socket Plug-B.I.
20	142504	1	3/4" B.I. Elbow 90°
21	142709	1	3/4" N.P.T. x 2" Lg Nipple – Black Iron
22	128099	1	3/4" x 3/4" Redundant Gas Valve
23	152506	1	1/2" x 1/2" Black Iron Street Elbow
24	312213	1	Burner Box Top Heat Shield
25	142707	1	1/2" x 1-1/2" Nipple
26	812057	1	Heat Shield

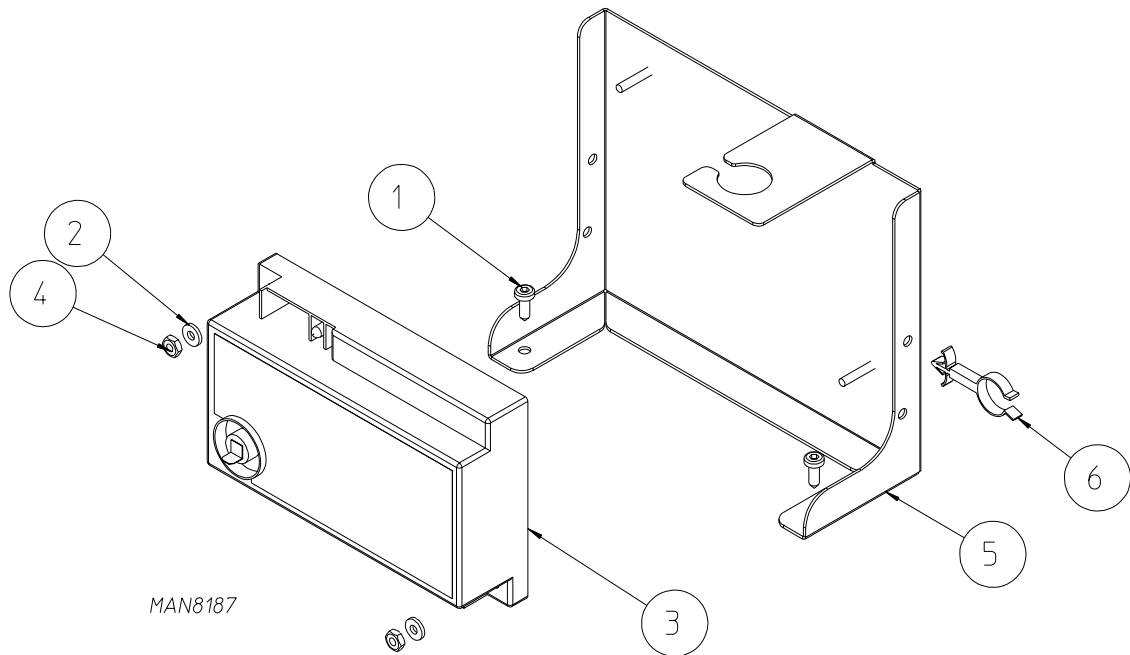

<u>Illus. No.</u>	<u>Part No.</u>	<u>Qty.</u>	<u>Description</u>
1	150331	2	#8-18 x 1/2" Pan Head TORX® Screw
2	153017	2	#6 S.A.E. Washer
3	128937	1	Direct Spark Ignition Module 3 Tries (CSA approved dryers)
	128942	1	Direct Spark Ignition Module 3 Tries (CE approved dryers)
4	152013	2	#6-32 Hex Nut
5	845756	1	Direct Spark Ignition Module Mounting Plate Assembly
6	121502	1	1/2" Wire Standoff

Electric Oven Assemblies

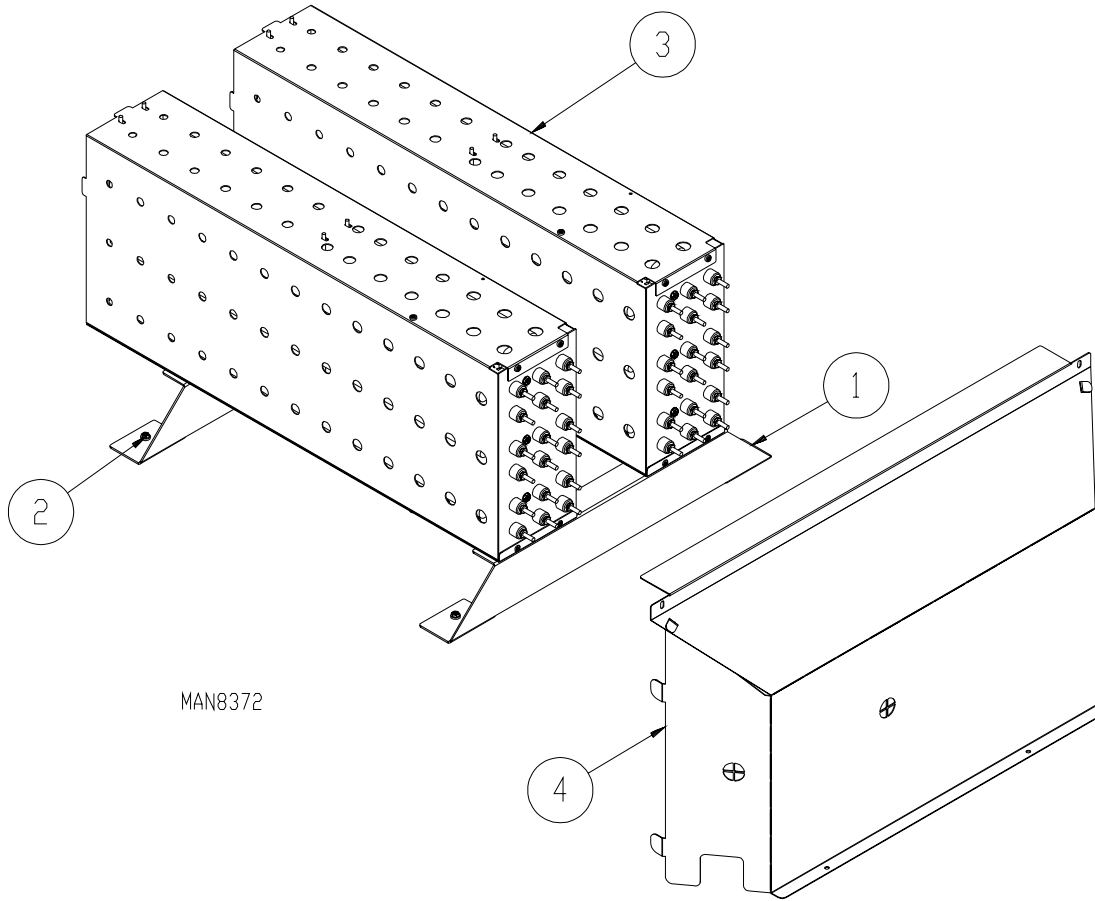

MAN8372

Illus. No.	Part No.	Qty.	Description
1	312249	2	Electric Oven Support
2	150309	4	#10-16 x 1/2" Hex Head TEK Crimp Srew
3	805101	2	Electric Oven Assembly 200-416V
	817833	2	Electric Oven Assembly 440-480V
	119997	2	22 kW Electric Element Only 200-416V
	119992	2	22 kW Electric Element Only 440-480V
4	312244	1	Electric Heat Shield

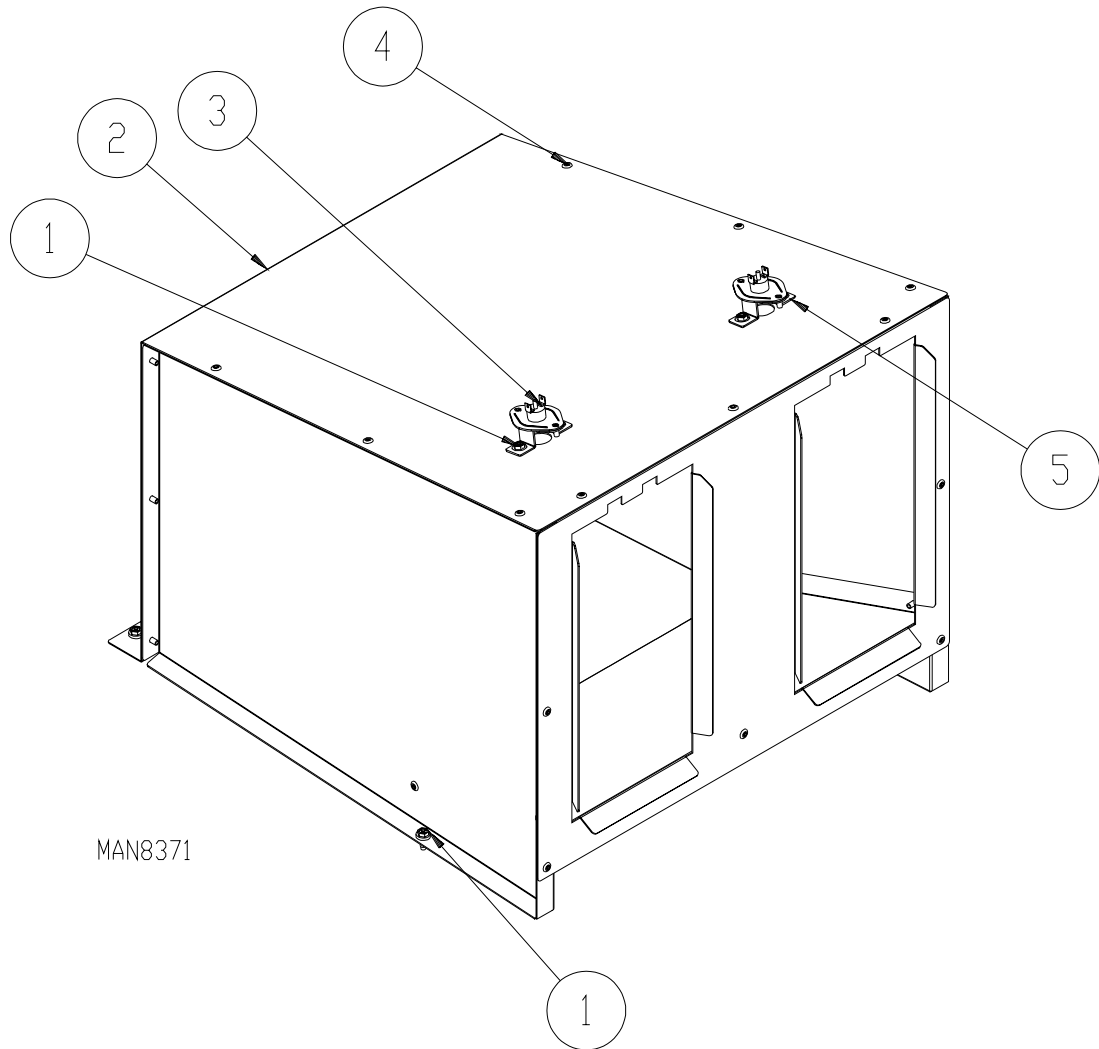

Illus. No.	Part No.	Qty.	Description
1	150309	8	#10-16 x 1/2" Hex Head TEK Crimptite Screw
2	312254	1	Electric Burner Box Assembly
3	130201	2	330° F Manual Reset Thermostat
4	154211	-	5/32" Buttonhead Rivet
5	318974	2	Burner Hi-Limit Mount

Electric Heat Contactor Box

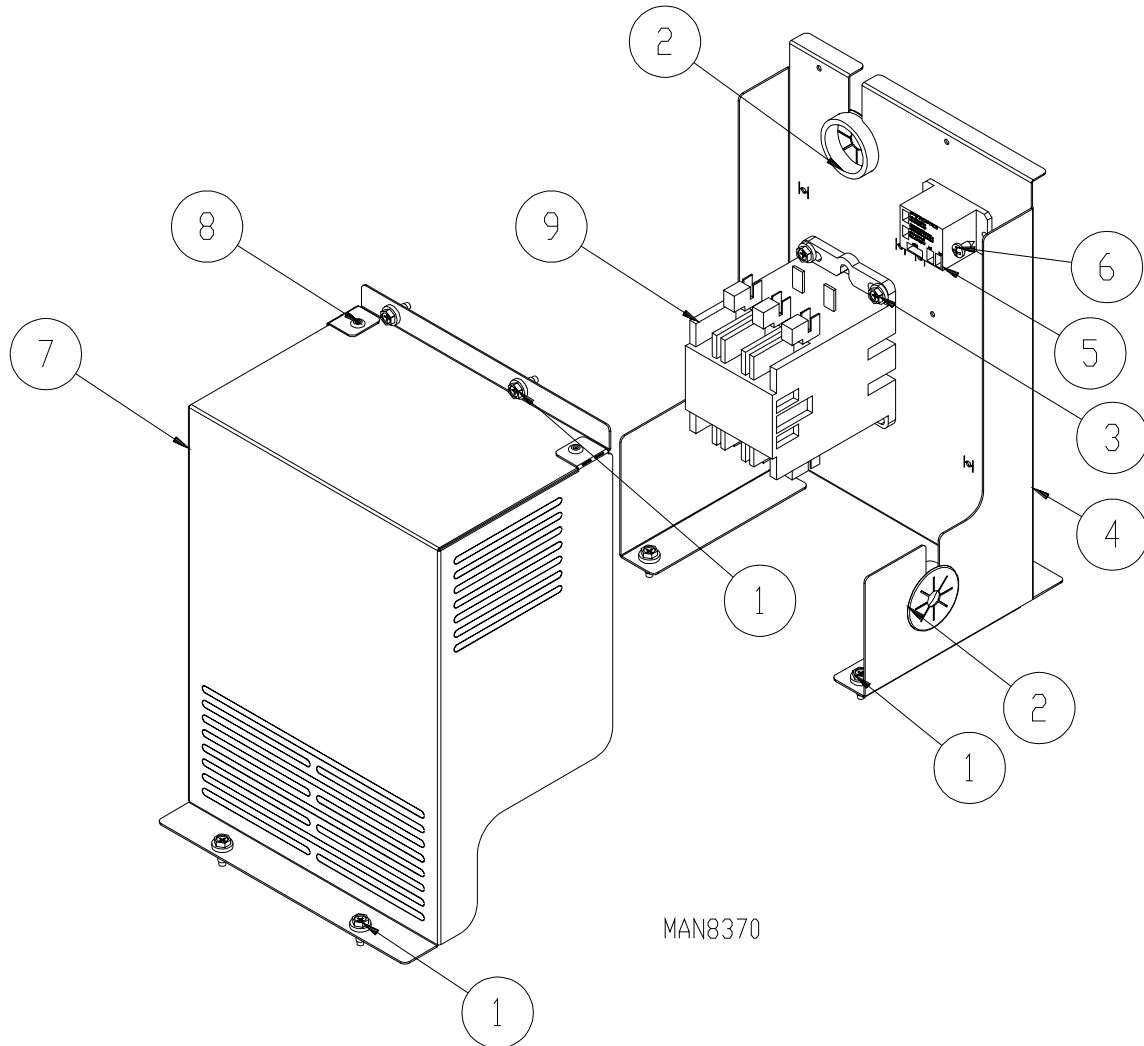

<u>Illus. No.</u>	<u>Part No.</u>	<u>Qty.</u>	<u>Description</u>
1	150309	8	#10-16 x 1/2" Hex Head TEK Crimptite Screw
2	121410	2	1-3/8" Universal Bushing
3	150311	3	#10-16 x 3/4" Hex Head TEK Crimptite
4	312245	1	Electric Heat Contactor Bracket
5	131428	1	Relay SPTD 24 VAC Panel Mount
6	150301	2	#8-18 x 7/16" Phillips Pan Head TEK Screw
7	312246	1	Heat Contactor Cover
8	154200	2	5/32" Pop Rivet
9	131378	1	65A 24V Contactor (for 380V-480V dryers)
	131363	2	75A 24V Contactor (for 208V dryers)
	131362	1	120A 24V Contactor (for 220V-240V dryers)

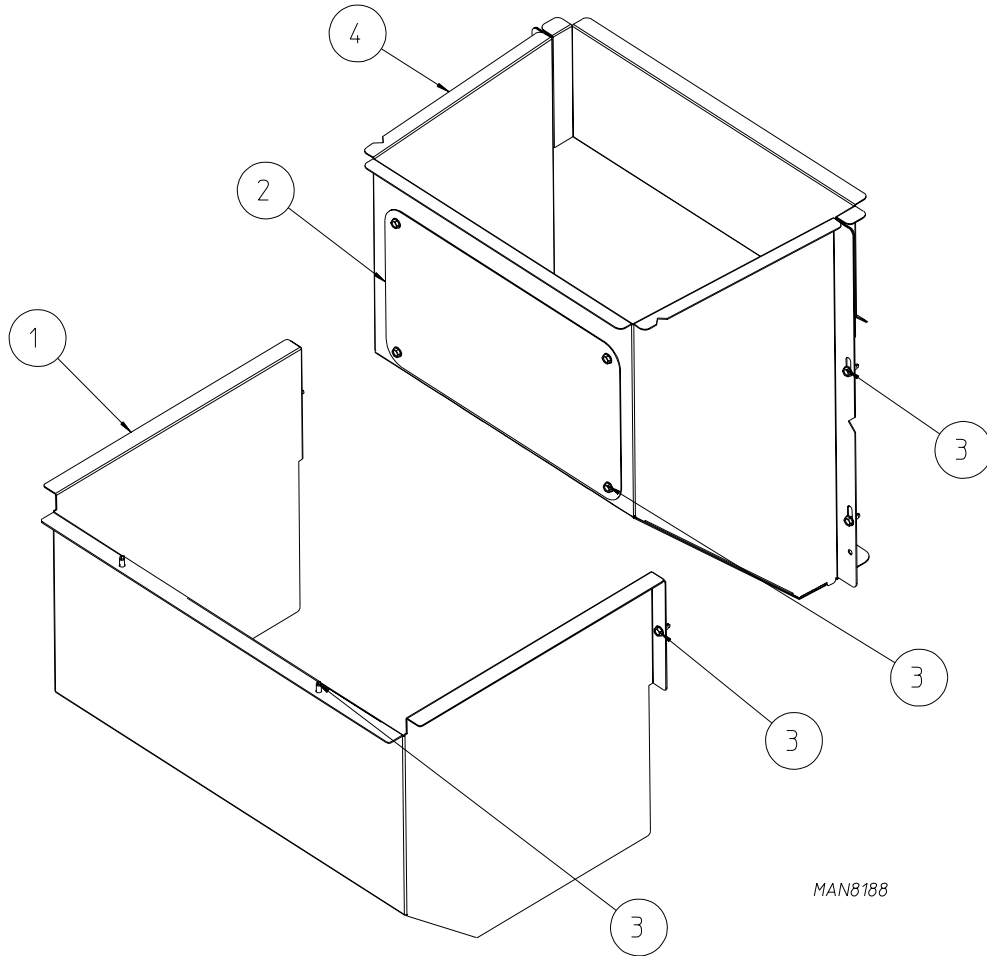

MAN8188

<u>Illus. No.</u>	<u>Part No.</u>	<u>Qty.</u>	<u>Description</u>
1	312095	1	Preheat Rear Conduit
2	312081	1	Rear Heat Duct Cover
3	150300	8	#10-16 x 1/2" Heat Washer TEK Screw
4	812010	1	Rear Heat Duct (for gas and electric models)
	812105	1	Rear Heat Duct (for steam models)

Steam Coil Assembly

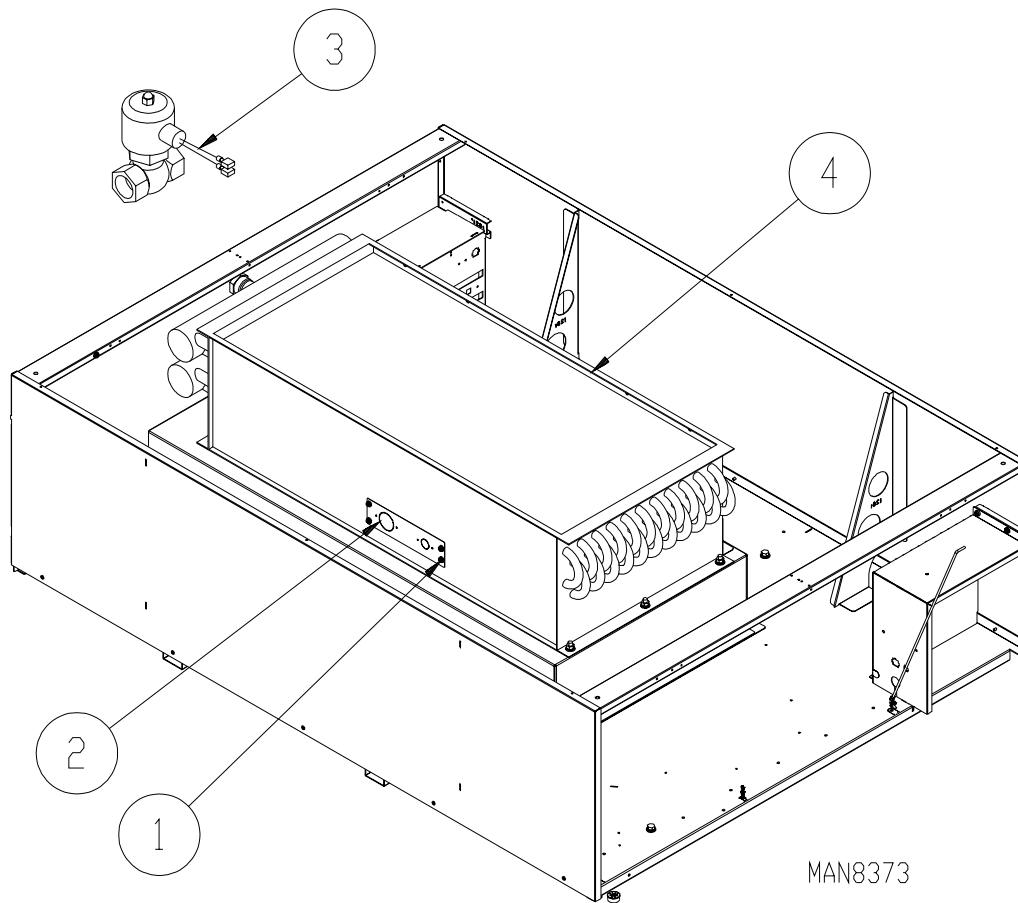

<u>Illus. No.</u>	<u>Part No.</u>	<u>Qty.</u>	<u>Description</u>
1	150309	4	#10-16 x 1/2" Hex Head TEK Crimptite
2	311590	1	Steam Phase 7 S.A.F.E. Sprinkler Plate
3	812113	1	1" Steam Solenoid Valve 24V
4	165090	1	Copper Steam Coil

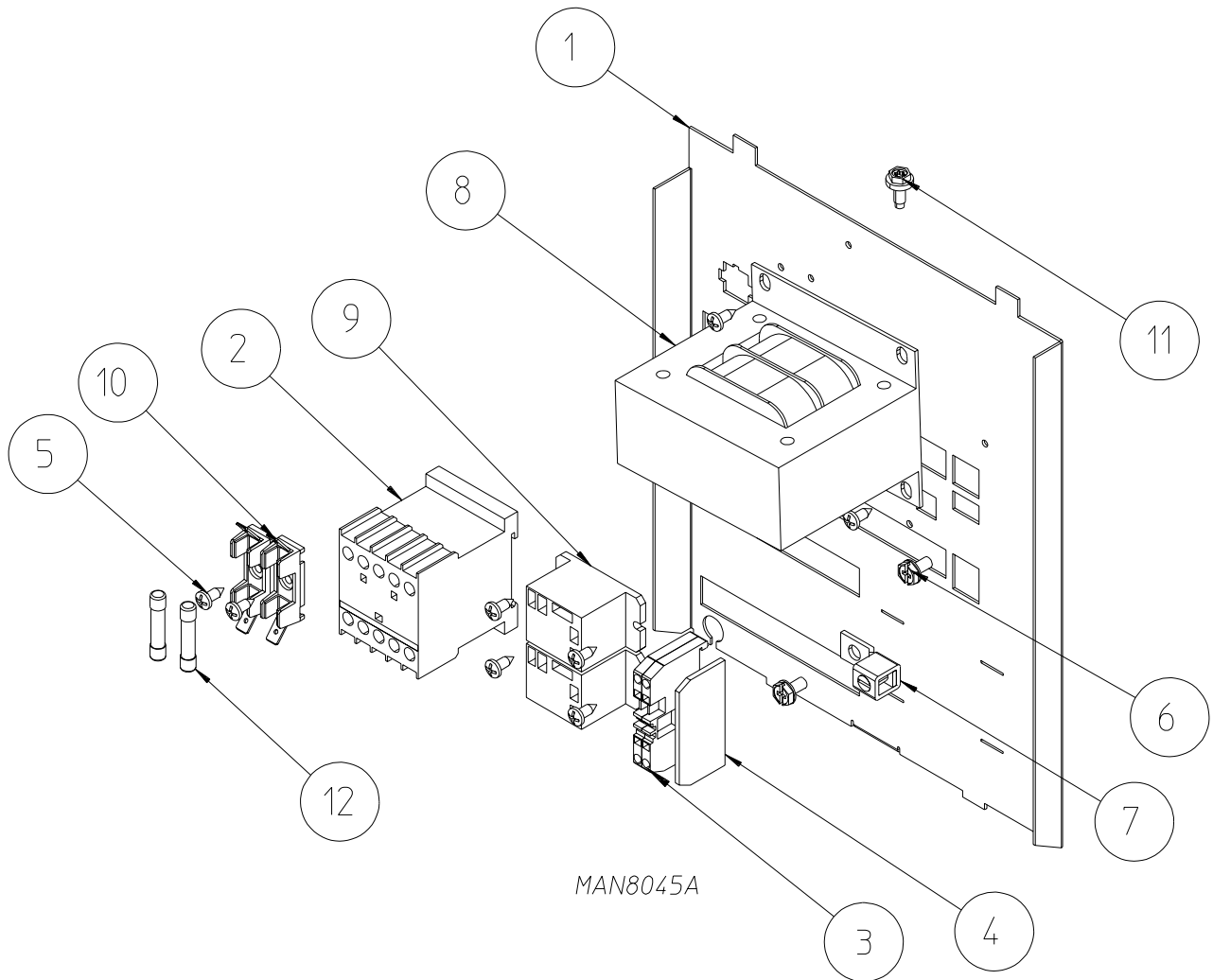

<u>Illus. No.</u>	<u>Part No.</u>	<u>Qty.</u>	<u>Description</u>
1	398301	1	Electrical Panel ONLY
2	131394	1	3-Pole Contactor
3	120758	-	2 Cod. Thru Terminal Block
4	120787	1	End Plate
5	150301	-	#8-18 x 7/16" Phillips Pan Head TEK Screw
6	120910	2	Green Ground Screw
7	121010	1	L70 14-4 Terminal Lug
8	132109	1	Transformer Assembly (120-240 volt)
	132111	1	Transformer Assembly (380-460 volt)
9	131428	-	Relay SPDT 24 VAC Panel Mount
10	136008	-	Fuse Holder (120-240 volt)
	136037	-	Fuse Holder (380-480 volt)
11	150297	1	#10-16 x 0.5 Hex Washer TEK Screw (green)
12	136101	-	.8-amp Slo-Blo Fuse (120-240 volt)
	136122	-	1.50-amp Time Delay Fuse (380-480 volt)

Sail Switch Assembly

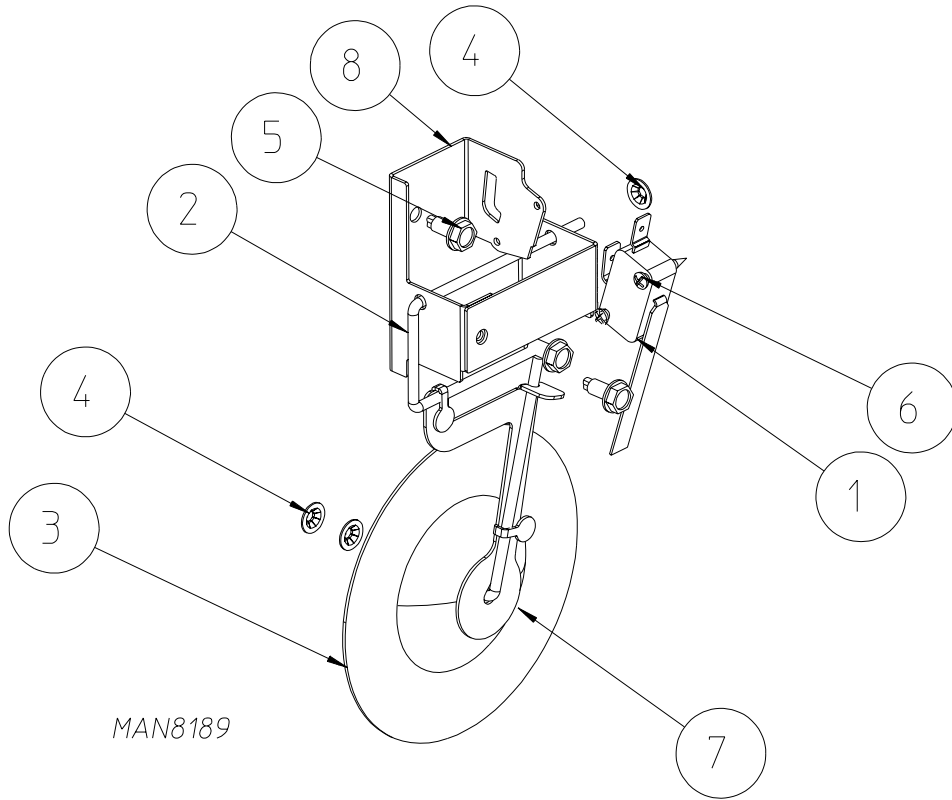

<u>Illus. No.</u>	<u>Part No.</u>	<u>Qty.</u>	<u>Description</u>
1	122200	1	Sail Switch ONLY
	812101	1	Sail Switch Assembly (includes illus. nos. 1 through 8)
2	312223	1	Single-Piece Sail Switch Actuator Rod
3	319206	1	Damper with Nipple
4	154002	3	1/8" Push-On Fastener
5	150300	3	#10-16 x 1/2" Hex Washer TEK Screw
6	150303	2	#4 3/4" Pan Head A Machine Screw
7	312230	1	Sail Switch Damper Stop
8	312224	1	Sail Switch Bracket

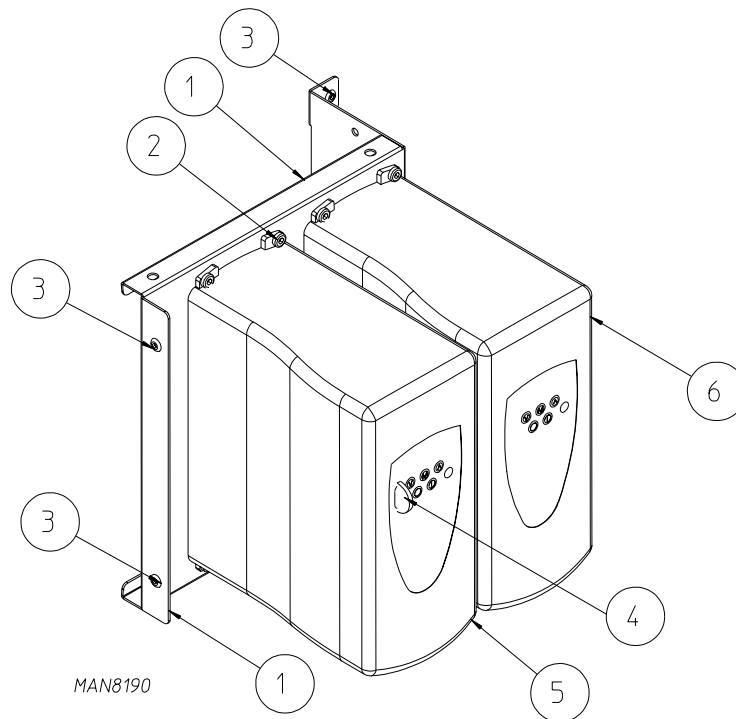

Illus. No.	Part No.	Qty.	Description
1	312078	1	VFD Mount
2	150331	8	#8-18 x 1/2" Pan Head
3	154200	4	5/32" Pop Rivet
4	181164	1	Logicstick Sk PLC Program (only used with models mfd. prior to March 18, 2015)
5	884549	1	VFD for 120 Volts (for models mfd. as of March 8, 2015)
	884550	1	VFD for 200-240 Volts (for models mfd. as of March 18, 2015)
	884552	1	VFD for 380-480 Volts (for models mfd. as of March 18, 2015)
	115612*	1	Display / Keypad for M400 Inverter
	181150	1	VFD for 120 Volts (for models mfd. prior to March 18, 2015)
	181173	1	VFD for 200-240 Volts (for models mfd. prior to March 18, 2015)
	181179	1	VFD for 380-480 Volts (for models mfd. prior to March 18, 2015)
6	884631	1	VFD for Fan 120 Volts (for models mfd. as of March 18, 2015)
	884630	1	VFD for Fan 200-240 Volts (for models mfd. as of March 18, 2015)
	884629	1	VFD for Fan 380-480 Volts (for models mfd. as of March 18, 2015)
	181150	1	VFD for Fan 120 Volts (for models mfd. prior to March 18, 2015)
	181175	1	VFD for Fan 200-240 Volts (for models mfd. prior to March 18, 2015)
	181174	1	VFD for Fan 380-480 Volts (for models mfd. prior to March 18, 2015)

* Not illustrated.

Outer Top / Back Guard Assemblies

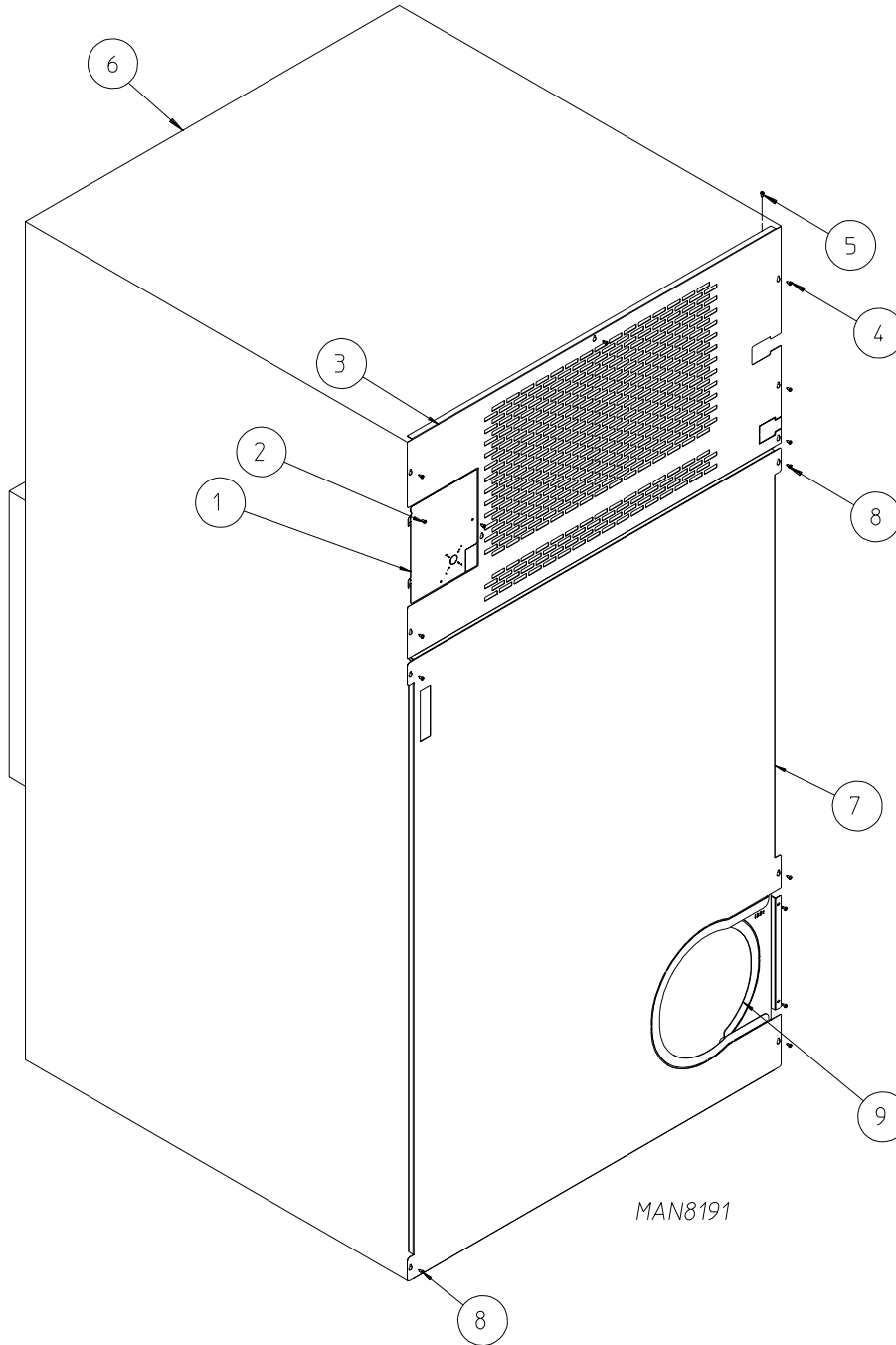

<u>Illus. No.</u>	<u>Part No.</u>	<u>Qty.</u>	<u>Description</u>
1	322935	1	Back Electrical Box Cover
2	154200	1	Pop Rivet
3	312059	1	Top Back Guard (gas models)
	312247	1	Top Back Guard (electric models)
4	150301	6	#8-18 x 7/16" Pan Head Screw
5	150301	12	#8-18 x 7/16" Pan Head Screw
6	312080	1	Outer Top
7	312058	1	Bottom Back Guard
8	150301	10	#8-18 x 7/16" Pan Head Screw
9	312084	1	Exhaust Guard

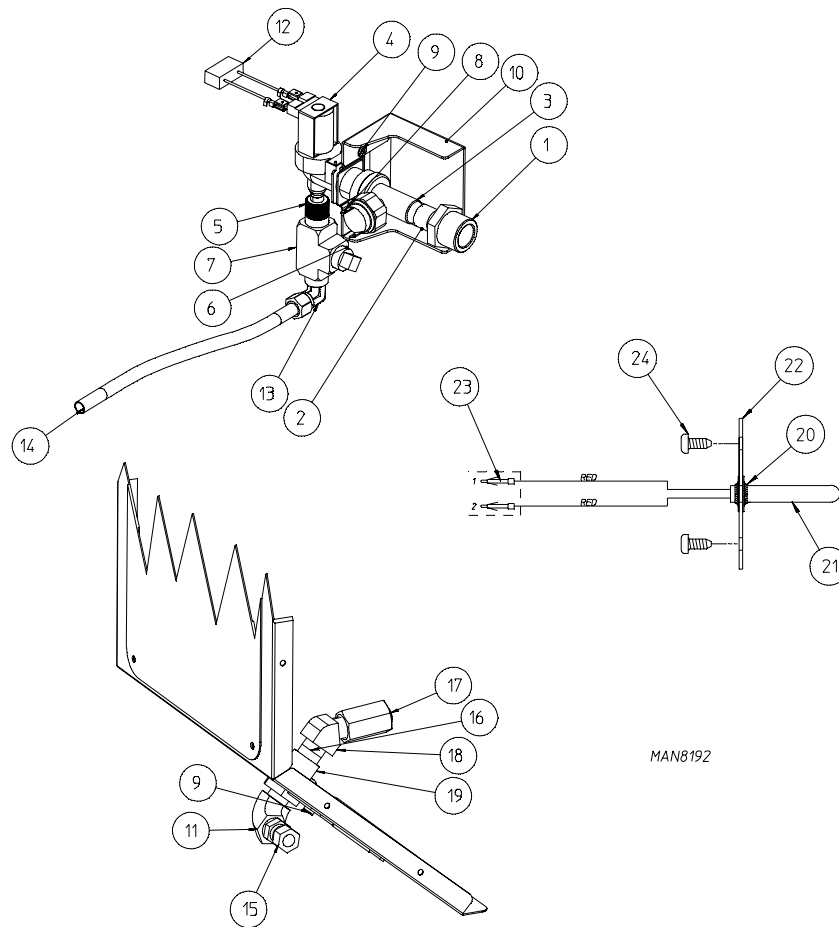

MAN8192

Illus. No.	Part No.	Qty.	Description
1	143356	1	3/4" NH Male x 3/8" F.N.P.T. Brass Bushing
	143263	1	0.750 x 0.375 Brass Reducing Bushing (50 Hz models only)
2	143348	1	3/8" x 1-1/2" Brass Nipple
3	143182	1	0.75 GHT x 0.125 x 0.375 N.P.T. Brass Tee
4	165119	1	S.A.F.E. Water Inlet Valve
5	143183	1	0.4375-20 x 0.375 N.P.T. Brass Adapter
6	143251	1	0.375 MPT Brass Plug
7	143220	1	0.375 F.P.T. Brass Tee
8	136987	1	Water Jet Pressure Switch
9	150331	6	#8-18 x 1/2" Pan Head TORX® Screw
10	317180	1	S.A.F.E. Valve Bracket
11	143155	1	0.375 Brass Street Elbow
12	824081	1	R.C. Network Assembly
13	143320	1	0.375 Comp x 0.375 M.N.P.T. Brass Elbow
14	143099	28	0.375 Soft Copper Tubing 8.5" (sold by the inch)
15	143208	1	0.375 Comp x 0.375 M.P.T. Connector
16	143241	1	0.375 Close Brass Nipple
17	143581	1	Fire Suppression Nozzle
18	143301	2	0.375 Brass 45° Street Elbow
19	143257	1	0.375 Bulkhead Adapter
20	154007	2	Fastener
21	819188	1	S.A.F.E. Probe Assembly (includes illus. nos. 20 through 24)
22	185428	1	Mounting Plate
23	122712	2	Pin
24	150331	2	#8-18 x 1/2" TORX®

Additional Parts Available

<u>Part No.</u>	<u>Description</u>
112280	“Clean Lint Screen” Label
114001	“CAUTION – Exhaust / Lint Screen” Label
114006	“WARNING – Fire Hazards” Label
120100	3/8” Straight (BX) Connector
120300	3/8” x 45° (BX) Connector
120400	3/8” Red Jacket (BX) Insulator
120500	3/8” Jiffy Clip (BX retainer clip)
120600	3/8” Greenfield (BX)
120707	(2-Position) Terminal Strip
120708	(3-Position) Terminal Strip
120800	1/4” In-Line Connector
120802	Red Butt Connector
120902	#74B Wire Nut
120903	Crimp-On Wire Nut
121014	1/4” Insulated (female) Terminal
121026	Tab Receptacle Combination
121499	5-1/2” Harness Tie
121500	8” Harness Tie
122804	Manometer (hydro gauge) for Measuring Gas Pressure
404502	White Brush-In-Cap Bottle Touch-Up Paint

